



BUILDING AND CODES  
P: 315-376-5377 | F: 315-377-3137

7660 North State Street  
Lowville, NY 13367  
lewiscounty.org

## **SOLID FUEL BURNING DEVICE & CHIMNEY BUILDING PERMIT APPLICATION**

Dear Applicant:

Attached is a Lewis County Solid Fuel Burning Device & Chimney Building Permit Application. This application is for use only in communities where the County of Lewis is responsible for enforcement of the Building Codes of New York State. The permit applied for with this form applies only to the Building Codes of New York State and has no bearing on the other local, state, or federal regulations, such as zoning or floodplain ordinance, etc.

**The permit fee must be submitted to the Lewis County Building & Codes Office with the completed application. Please make all checks payable to the Lewis County Clerk and mail to the Lewis County Building & Codes Department, 7660 North State Street, Lowville, New York 13367.**

The permit and all correspondence will be mailed to the owner at the address indicated on the application.

It is the responsibility of the owner to see that the Lewis County Code Enforcement Officer is notified when the project will be ready for the next inspection.

**If you have any questions, please contact the Lewis County Building & Codes Office at (315) 376-5377.**

Sincerely,

A handwritten signature in black ink that reads "Ward Dailey". The signature is written in a cursive, slightly slanted style.

Ward Dailey  
Senior Code Enforcement Officer

Attachment

LEWIS COUNTY BUILDING & CODES DEPARTMENT  
LEWIS COUNTY COURT HOUSE  
7660 N. STATE ST.  
LOWVILLE, NEW YORK 13367  
Phone: (315) 376-5377 Fax: (315) 377-3137

Permit No. \_\_\_\_\_

## Solid Fuel Permit Application

Date \_\_\_\_\_

Census Code \_\_\_\_\_ **W** \_\_\_\_\_

Tax Map # \_\_\_\_\_

Construction Start Up Date \_\_\_\_\_ Application Fee \$ \$40.00

Property Owner's Name \_\_\_\_\_ Phone \_\_\_\_\_

Mailing address \_\_\_\_\_

Applicant / Contractor Name \_\_\_\_\_ Phone \_\_\_\_\_

Mailing address \_\_\_\_\_

Project Address (911 address) \_\_\_\_\_ Town \_\_\_\_\_

Value of Work (materials & labor) - \$ \_\_\_\_\_

### **PROPOSED ACTIVITY** (Check all appropriate)

- Install Solid Fuel Burning Appliance. (Complete Section A)
- Installation of Chimney for Solid Fuel Burning Appliance. (Complete Section B)
- Connection of Solid Fuel Burning Device to Existing Chimney or Passage of Connectors or Chimney through wall or ceiling. (Complete Section C)

### **TYPE OF CONSTRUCTION OF STRUCTURE WHERE SOLID FUEL BURNING APPLIANCE OR CHIMNEY IS TO BE INSTALLED**

- Mobile Home
- Masonry
- Steel
- Wood Frame
- Other

---

### **SECTION A – SOLID FUEL BURNING APPLIANCE**

**APPLIANCE TO BE INSTALLED BY:**  Property owner/applicant  Professional

### **THIS APPLIANCE WILL BE CONNECTED TO:**

- New Chimney (See Section B)
- Existing Chimney
- Previously used for Solid Fuel Appliance
- Previously used for Non-Solid Fuel Equip.

**TYPE OF SOLID FUEL BURNING APPLIANCE**

**IS THIS APPLIANCE LISTED AS APPROVED BY A CERTIFYING AGENCY**

- Fireplace
  - Masonry
  - Zero Clearance
- Fireplace Insert
- Freestanding Stove

NO  YES AGENCY \_\_\_\_\_

Manufacturer: \_\_\_\_\_

Model: No. or Name \_\_\_\_\_

- |                                       |                                  |  |
|---------------------------------------|----------------------------------|--|
| <input type="checkbox"/> Hearth Stove | <b>FUEL TO BE USED:</b>          | <b>ROOM APPLIANCE IS TO BE LOCATED IN:</b>                                     |
| <input type="checkbox"/> Furnace      | <input type="checkbox"/> Wood    | <input type="checkbox"/> Basement <input type="checkbox"/> Living/Family Rooms |
| <input type="checkbox"/> Boiler       | <input type="checkbox"/> Coal    | <input type="checkbox"/> Furnace Room <input type="checkbox"/> Kitchen         |
| <input type="checkbox"/> Other _____  | <input type="checkbox"/> Pellets | <input type="checkbox"/> Other _____   |

**USE:** (Check all that apply)  Primary Heat  Decorative  Supplementary Heat  Cooking  
Appliance Flue Discharge Size (diameter in inches) \_\_\_\_\_

TYPE OF FLOOR PROTECTION UNDER AND AROUND APPLIANCE (Describe) \_\_\_\_\_

IF SINGLE WALL STOVEPIPE IS USED BETWEEN APPLIANCE AND CHIMNEY, GIVE DISTANCE FROM PIPE TO COMBUSTIBLE SURFACES. \_\_\_\_\_ INCHES

**SECTION B – CHIMNEY FOR SOLID FUEL BURNING DEVICE**

**CHIMNEY TO BE INSTALLED BY:**

Property owner/applicant  Professional: Name \_\_\_\_\_

Address \_\_\_\_\_

**TYPE OF CHIMNEY CONSTRUCTION:**  Masonry  Steel

Manufacturer: \_\_\_\_\_ Size & Depth of Footer for Masonry Chimney \_\_\_\_\_

CHIMNEY WILL BE: External  Internal

Size of Flue (in inches) \_\_\_\_\_

Type of Liner:  Clay flue  Steel  Other \_\_\_\_\_

Type of Material Used to Support and Brace Chimney \_\_\_\_\_

CHIMNEY WILL EXTEND \_\_\_\_\_ FT. ABOVE ROOF WHERE LOCATED

CHIMNEY WILL EXTEND \_\_\_\_\_ FT. ABOVE PEAK OF ROOF

IS THERE MORE THAN ONE HEATING APPLIANCE PER CHIMNEY FLUE PROPOSED?  Yes  No

**STATEMENT OF WORKERS COMPENSATION**

**(HOMEOWNER)**

**Under penalty of perjury**, I certify that I am the owner of the residence listed on the building permit that I am applying for, and I am not required to show specific proof of workers' compensation insurance coverage for such residence because **(please circle one)**:

- A) I am performing all the work for which this building permit is issued.
- B) I am not hiring, paying or compensating in any way, the individual(s) that is (are) performing all the work for which this building permit is issued or helping me perform such work.
- C) I have a homeowners insurance policy that is currently in effect and covers the property listed on the attached building permit AND am hiring or paying individuals a total of less than 40 hours per week (aggregate hours for all paid individuals on the jobsite) for which this building permit is issued.

I understand that I will have to acquire Worker's Compensation if, I need to hire or pay individuals a total of 40 hours or more per week (aggregate hours for all paid individuals on the jobsite) for work indicated on this building permit; **OR** have a general contractor, performing the work listed on the building permit that I am applying for, provide appropriate proof of workers' compensation coverage or proof of exemption from that coverage on forms approved by the Chair of the NYS Workers' Compensation Board to the government entity issuing the building permit if the project takes a total of 40 hours or more per week (aggregate hours for all paid individuals on the jobsite) for work indicated on this building permit.

\_\_\_\_\_  
Signature of Homeowner

\_\_\_\_\_  
Date Signed

\_\_\_\_\_  
Homeowners Name Printed

**STATEMENT OF WORKERS COMPENSATION**

**(CONTRACTOR)**

As the contractor of record for this permit application, I understand that I am responsible for proof of Workers Compensation or proof of Exemption from Workers Compensation. I agree I will provide proof of Workers Compensation or proof of Exemption to the Lewis County Fire Prevention and Building Codes office. I understand that the proof will be filed for a period of 1 year.

\_\_\_\_\_  
Signature of Contractor

\_\_\_\_\_  
Date Signed

\_\_\_\_\_  
Contractors Name Printed

**STATEMENT OF ENVIRONMENTAL CONCERN**

**(HOMEOWNER)**

This Statement confirms that I have read and been made aware that the **New York State Department of Environmental Conservation** requires a State Pollution Discharge Elimination System Permit (S.P.D.E.S.) be obtained for disturbance of property greater than one (1) acre; this is to include driveways, location of house and all outbuildings & pools.

For more information, you are strongly urged to contact the D.E.C. Bureau of Water Permits at 518-402-8111 or online at [www.dec.state.ny.us/website/dow/mainpage.htm](http://www.dec.state.ny.us/website/dow/mainpage.htm)

State imposed fines for a violation of this law can be a substantial \$37,500. per day. If in doubt, call New York State Department of Environmental Conservation.

\_\_\_\_\_  
Signature of Homeowner

\_\_\_\_\_  
Date Signed

\_\_\_\_\_  
Homeowners Name Printed

**Section B** (continued)

CHIMNEY WILL BE \_\_\_\_\_ INCHES FROM COMBUSTIBLES OUTSIDE

CHIMNEY WILL BE \_\_\_\_\_ INCHES FROM COMBUSTIBLES INSIDE

FLUE JOINTS WILL BE SEALED TOGETHER

BY \_\_\_\_\_

**SECTION C – CONNECTORS AND WALL OR CEILING PASSAGES**

*Using space below or on a separate sheet of paper -*

Diagram any wall or ceiling and/or roof passages including size of connectors, collars, etc. and distance to combustibles.

Diagram proposed installation of Solid Fuel Burning Appliance including distances from floor, ceiling, walls, and all combustible materials

**CLEARANCES** (See numbers on diagram at right)

1.	_____ Inches	Side of unit to nearest wall
2.	_____ Inches	Rear of unit to wall
3.	_____ Inches	Top of stove pipe to ceiling
4.	_____ Inches	Bottom of unit to floor
5.	_____ Inches	From loading door to front edge of floor protection
6.	_____ Inches	Size of pipe used (diameter)
7.	_____ Inches	Size of thimble or roof joist shield
8.	_____ Feet	Total stove pipe length
9.	<input type="checkbox"/> Yes <input type="checkbox"/> No	Do these distances comply with the manufacturer's standards?

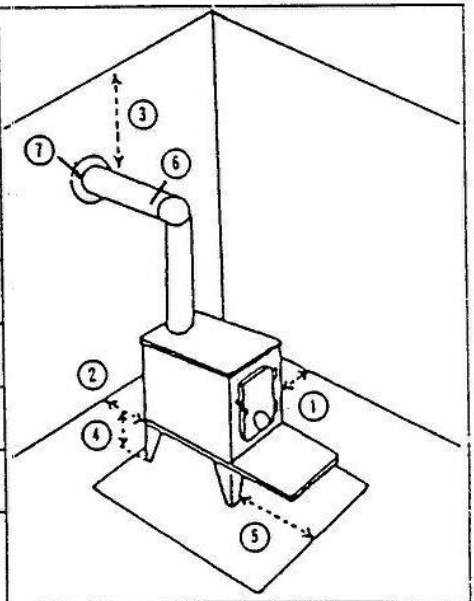

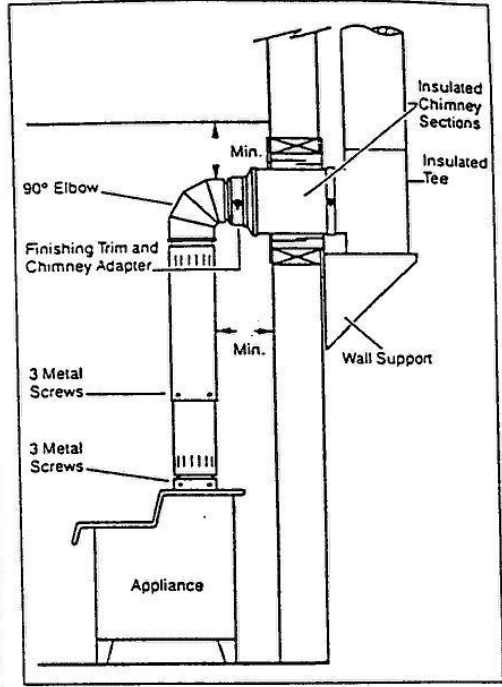
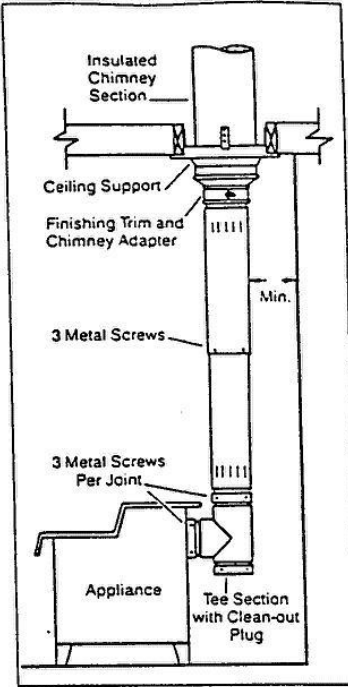
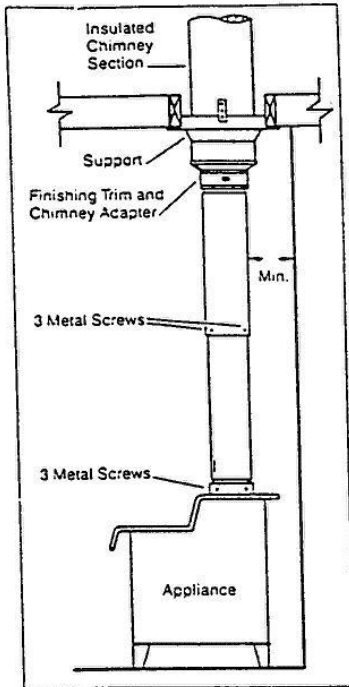

**INTERIOR INSTALLATION**

**EXTERIOR INSTALLATION**

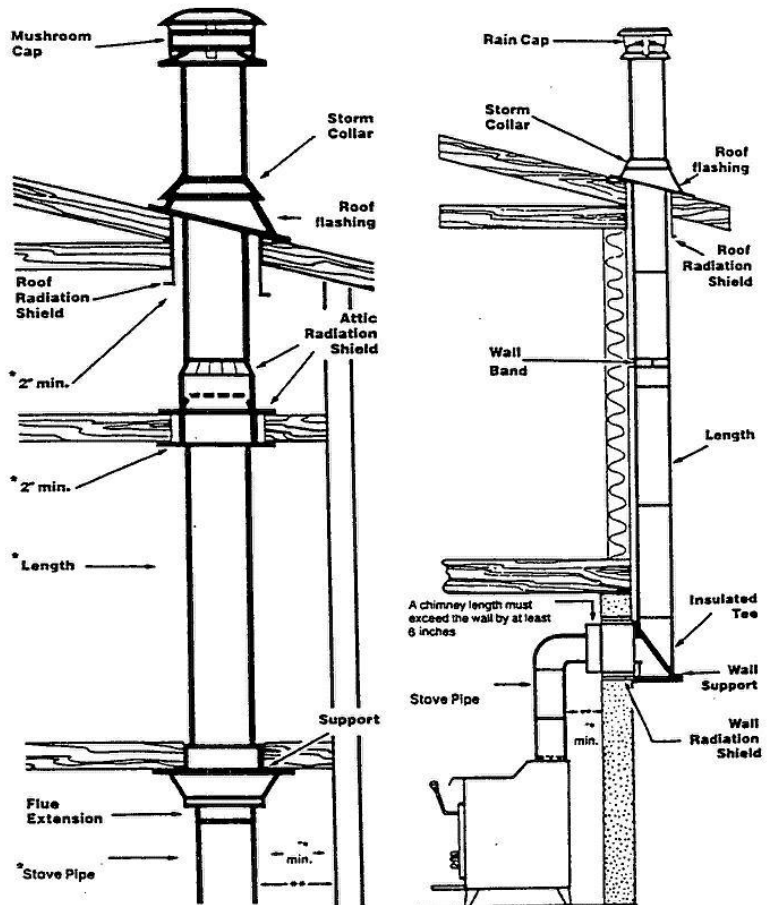
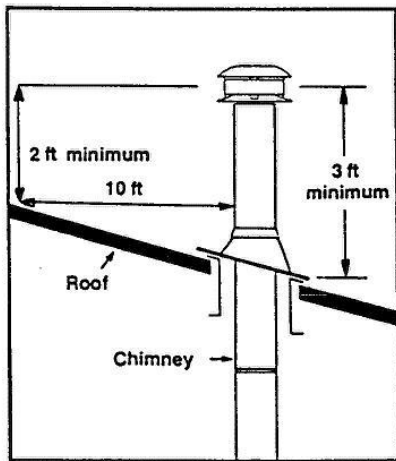

\* SEE APPLIANCE MANUFACTURER INSTALLATION INSTRUCTIONS FOR THIS CLEARANCE.

\*\*The required minimum clearance for single wall stove pipe is 18 inches.

- (A) The applicant shall notify the County of any changes in the information contained in the application during the period for which the permit is in effect. A permit will be issued when the application has been determined to be complete and when the proposed work is determined to conform to the requirements of the Uniform Code. The authority conferred by such permit may be limited by condition, if any, contained therein.
- (B) A building permit issued pursuant to this Part may be suspended or revoked if it is determined that the work to which it pertains is not proceeding in conformance with approved plans, the Uniform Code, or with any condition attached to such permit, or if there has been a misrepresentation or falsification of a material fact in connection with the application for the permit.
- (C) **A building permit issued pursuant to this Part shall expire one year from the date of issuance or upon the issuance of a certificate of occupancy whichever occurs first.**

I HEREBY CERTIFY THAT I HAVE READ AND EXAMINED THIS APPLICATION AND KNOW THE SAME TO BE TRUE AND CORRECT. ALL PROVISIONS OF LAWS AND ORDINANCES GOVERNING THIS TYPE OF WORK WILL BE COMPLIED WITH WHETHER SPECIFIED HEREIN OR NOT. THE GRANTING OF A PERMIT DOES NOT PRESUME TO GIVE AUTHORITY TO VIOLATE OR CANCEL THE PROVISIONS OF ANY OTHER STATE OR LOCAL LAW REGULATING CONSTRUCTION OR THE PERFORMANCE OF CONSTRUCTION.

\_\_\_\_\_  
Signature of Applicant or Authorized Agent

\_\_\_\_\_  
Date

I, the undersigned, Code Enforcement Officer of the County of Lewis, hereby (approve) (deny) the within application for building permit.

\_\_\_\_\_  
Date

\_\_\_\_\_  
Code Enforcement Officer

ALL CONSTRUCTION SHALL CONFORM TO THE NEW YORK UNIFORM FIRE PREVENTION & BUILDING CODE, THE NEW YORK STATE ENERGY CODE AND ALL TOWN AND LOCAL ZONING AND SANITARY CODES.